

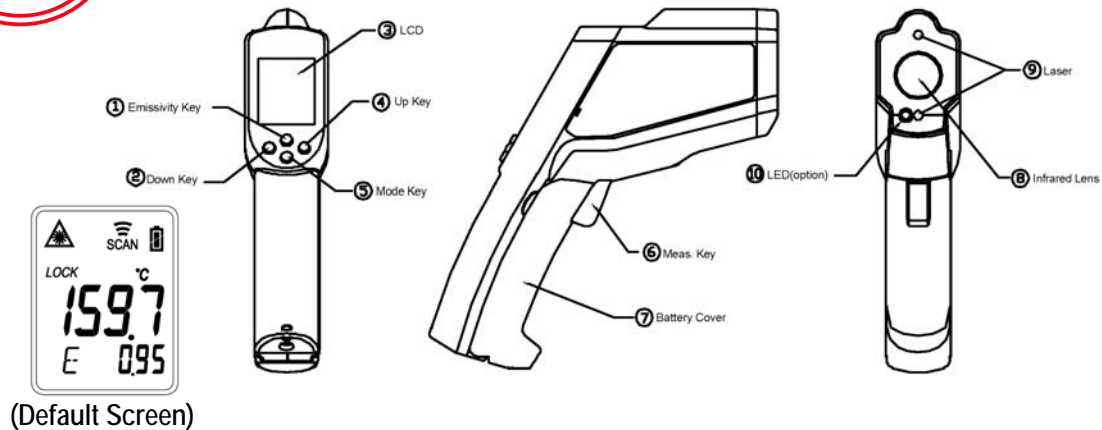

QT4242L Thermometer Operating Instructions

Keep away from children. Do not use for medical applications.



Simply aim the thermometer at the measure target with Lens (⑧) and pull Trigger (⑥) to display the surface temperature. The Distance:Spot ratio is at least 30:1. The two laser points highlight the measured target spot diameter. Make sure the measured target area exceeds the field-of-view.

NOTE: The thermometer will automatically shut OFF if left idle for more than 60 sec.

FUNCTION

Press Emissivity key (①) for setting the emissivity

Press Emissivity key (①), then press Up key (④) or Down key (②) to **adjust emissivity**, then press Mode key (⑤) to confirm it. The emissivity can be changed from 0.10 (10E) to 1 (100E).

Press Mode key (⑤) for scrolling more display function as follows.

	Show the current emissivity value (the default emissivity is 0.95).
 	Press Mode key (⑤) for the Maximum (MAX) , Minimum (MIN) , Difference between MAX and MIN (DIF) and Average (AVG) modes. During the measurement, the particular Mode temperature reading will be displayed beside the Mode icon.
 	Press Up key (④) or Down key (②) key to change the High Alarm (HAL) or Lo Alarm (LAL) , then press Meas. key (⑥) to confirm it. For example: When the reading 26.9°C < LAL 27°C, the Low icon will flash and you will hear a beeping sound.

ADD VALUE

In MAX, MIN, DIF, AVG mode:	Press Up key (④) for LOCK mode ON/OFF . The lock mode is particularly useful for continuous monitoring of temperatures for up to 60 minutes.
	Press Down key (②) for °C or °F transferred.
In all modes: First hold on the Meas. key (⑥)	and press Up key (④) for backlight function ON/OFF .
	and press Down key (②) for laser function ON/OFF . (Flash light can be turned on in the same time as laser)



⚠ CAUTION

1. DO NOT LOOK DIRECTLY INTO THE TWO LASER BEAMS—PERMANENT EYE DAMAGE MAY RESULT.
2. USE EXTREME CAUTION WHEN OPERATING THE LASER.
3. NEVER POINT THE DEVICE TOWARDS ANYONE'S EYES.
4. KEEP OUT OF REACH OF CHILDREN.

STORAGE & CLEANING The thermometer should be stored at room temperature between -20 to $+65$ °C (-4 – 149 °F).

The sensor lens is the most delicate part of the thermometer. The lens should be kept clean at all times, care should be taken when cleaning the lens using only a soft cloth or cotton swab with water or medical alcohol. Allowing the lens to fully dry before using the thermometer. Do not submerge any part of the thermometer.

LCD ERROR MESSAGES

The thermometer features visual diagnostic messages as follows:



'Hi' or 'Lo' is displayed when the temperature being measured is outside of the settings of HAL and LAL.



'Er2' is displayed when the thermometer is exposed to rapid changes in the ambient temperature. 'Er3' is displayed when the ambient temperature exceeds 0°C (32°F) or $+50^{\circ}\text{C}$ (122°F). The thermometer should be allowed plenty of time (minimum 30 minutes) to stabilize to the working/room temperature.



Error 5–9, for all other error messages it is necessary to reset the thermometer. To reset it, wait for auto power off, remove the battery and wait for a minimum of one minute, reinsert the battery and turn on. If the error message remains please contact the Service Department for further assistance.



'Hi' or 'Lo' is displayed when the temperature being measured is outside of the measurement range.

BATTERIES

The thermometer incorporates visual low battery indication as follows:



'Battery OK': measurements are possible



'Battery Low': battery needs to be replaced, measurements are still possible

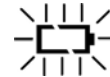

'Battery Exhausted': measurements are not possible

⚠ When the 'Low Battery' icon indicates the batteries are low, the batteries should be replaced immediately with AAA 1.5V batteries.

PLEASE NOTE: It is important to turn the instrument off before replacing the batteries, otherwise the thermometer may malfunction.

⚠ Dispose of used batteries promptly and keep away from children.

SPECIFICATION

Item	Non-contact Infrared Scan function
Measurement Range	-60 to $+871$ °C (-76 to $+1600$ °F)
Operating Range	0 to $+50$ °C (32 to $+122$ °F)
Accuracy ($T_{obj}=-33$ – 900°C , $T_{amb}=23\pm 3^{\circ}\text{C}$)	$\pm 2\%$ of reading or 2°C (4°F) whichever is greater
Emissivity Range	0.95 factory default; adjustable 0.1 to 1.00 in increments of 0.01
Resolution (-9.9 – 199.9°C)	0.1°C / 0.1°F
Response Time (90%)	1 second
Distance:Spot	30:1 (minimum)
Battery Life	Typ.180, min 140 hours continuous use (Alkaline, without Laser and Back Light)
Dimensions	47.0 x 197.0 x 203.3mm (1.8x7.7x8.0 inch)
Weight	386.1 grams (13.62 oz) including batteries (AAA*2pcs)

Note: Under an electromagnetic field of 3V/m from 90 to 360 MHz the maximum error is $\pm 10^{\circ}\text{C}$

⚠ EMC/RFI: Readings may be affected if the unit is operated within radio frequency electromagnetic field strength of approximately 3 volts per meter, but the performance of the instrument will not be permanently affected.



**TEL-TRU
MANUFACTURING CO.**
World-Class Instruments

408 St. Paul Street, Rochester, New York 14605
Phone: 585.232.1440 • 800.232.5335 • Fax: 585.232.3857
Email: info@teltru.com • Web: www.teltru.com