

TEL-TRU THERMOMETER CALIBRATOR PACKING INSTRUCTIONS

****IMPORTANT****

- Please keep the original carton and packing materials for re-certification service returns.
- Carefully pack your calibrator when shipping it back for re-certification service (see figure 1).
- **If you are ordering the recertification service via our Customer Support group** (585-232-1440 or 800-232-5335), you will obtain a Return Authorization Number (RMA#) from your Tel-Tru associate. Carefully pack up the unit(s), noting the RMA# on the outside of the box, and in the format "RMA XXXXXX". Ship the box to the factory at the address listed below.
- **If you are ordering the recertification service via our website**, you will find a six-digit order number at the top of your recertification purchase receipt. This is your Thermometer Re-calibration Reference (CR) number. Carefully pack up the unit(s), noting the CR# on the outside of the box, in the format "CR XXXXXX". Ship the box to the factory at the address listed below.

Ship to: Tel-Tru Manufacturing
ATTN: Customer Returns, RMA XXXX (or CR XXXXXX)
392 Saint Paul St.
Dock @ 10 Ward Street
Rochester, NY 14605

CALIBRATOR PACKING INSTRUCTIONS (FIGURE 1)

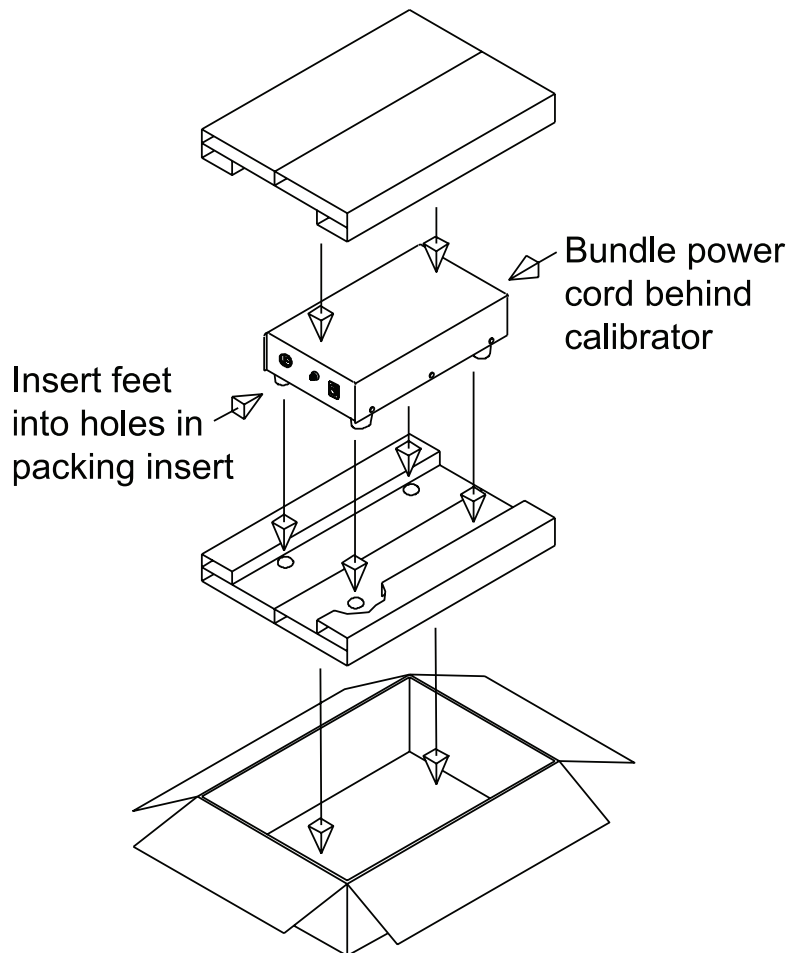

Tel-Tru Manufacturing Company

408 Saint Paul Street, Rochester, New York 14605

Phone: 585.232.1440 • 800.232.5335 • Fax: 585.232.3857 • Email: info@teltru.com • Web: www.teltru.com

PN 96100228

Rev1